

SMART UNIVERSAL SIGNAL CONDITIONER

SEM1700

- **DIRECT USB CONNECTION FOR CONFIGURATION**
- **Rtd, THERMOCOUPLE, mV, V, mA and SLIDEWIRE INPUTS**
- **ISOLATED UNIVERSAL VOLTAGE or CURRENT OUTPUT**
- **DUAL c/o RELAY OUTPUTS WITH PROGRAMMABLE DELAY**
- **UNIVERSAL AC DC POWER SUPPLY, 3 PORT ISOLATION**
- **USER TRIM / USER MANUAL CONFIGURATION PUSH BUTTONS**



INTRODUCTION

The SEM1700 is a new generation DIN rail mounted universal signal conditioner from Status Instruments. It has been designed to accept most common process and temperature sensor inputs and provide the user with a programmable current or voltage output signal plus dual relays with a programmable delay function. Isolation is provided between input, outputs and supply. All temperature ranges are linear to temperature. Both input and output loop excitation is provided as well as a fully universal power supply.

Designed for ease of use, our latest USB interface is fitted for quick and easy configuration. Just connect a standard USB cable between the SEM1700 and your PC. Using our free configuration software, your PC will automatically upload the existing configuration data and guide you through any changes you wish to make. To further help save time, the SEM1700 does not need to be wired to a power supply during the configuration process, it is powered via the USB interface from your PC.

The following parameters are configurable:

INPUT TYPE		SCALE / RATE	ANALOGUE OUTPUT	RELAY OUTPUTS	USER TRIM OPTIONS
RTD	Pt100 .00385 (IEC) Pt100 .00391 (IPTS-68) Pt100 .00392 (IPTS-68) Pt100 .00393 (ITS-90) Ni100 .00618 (DIN) Ni120 .00672 (Nickel A) Cu100 .00427 Cu53	°C / °F / °K Update Rate	Current (4 to 20) mA Preset (0 to 20) mA Preset User Programmable Range Voltage (0 to 10) V Preset User Programmable Range Fault Condition Up Scale Down Scale User Programmable Setting	RELAY 1 / RELAY2 Setpoint Hysteresis High Al Low Al High Con Low Con Off On Delay Off Delay	1. Off 2. Trim 3. Push Button Configuration
T/C	K, J, E, N, T, R, S, L,U, B, C(W5), D(W3), G(W)				
SLIDE WIRE	> 1K	Process Variable Scaling Update Rate	Output damping rise Output damping fall		
CURRENT (mA)	± 30 mA (4 to 20) mA Capability				
VOLTAGE	± 50 mV ± 200mV ± 1V ± 10V				
TAG ID.	Up to 15 Characters can be used				

SMART UNIVERSAL SIGNAL CONDITIONER

SPECIFICATION @20 °C

TEMPERATURE INPUTS

INPUT	RANGE	ACCURACY	STABILITY WITH TEMPERATURE
Thermocouples			
K	(-200 to 1370) °C (-320 to 2498) °F	1 Reading / Second ± 0.5 °C + (0.1 % of FRS)	±0.05 % FSR/°C
J	(-200 to 1200) °C (-320 to 2190) °F		
E	(-200 to 1000) °C (-320 to 1832) °F		
N	(-180 to 1300) °C (-292 to 2372) °F	4 Readings / Second ± 1.0 °C + (0.1 % of FRS)	±0.08 % FSR/°C
T	(-200 to 400) °C (-320 to 750) °F	10 Readings / Second ± 2.0 °C + (0.1 % of FRS)	±0.15 % FSR/°C
R *1 *2	(-10 to 1760) °C (-148 to 3200) °F		±0.10 % FSR/°C
S *1 *2			
L	(-100 to 600) °C (-148 to 1100) °F		±0.08 % FSR/°C
B *1 *2	(0 to 1600) °C (32 to 3000) °F		±0.10 % FSR/°C
U	(0 to 600) °C (32 to 1100) °F		±0.08 % FSR/°C
C(W5) *2	(0 to 2300) °C (32 to 4200) °F		±0.05 % FSR/°C
D(W3) *2			
G(W) *2			
RTD			
Pt100.00385 (IEC)	(-200 to 850) °C (-320 to 1560) °F	1 Reading / Second ± 0.15 °C + (0.05 % of FRS)	±0.015 % FSR / °C *3
Pt100 .00391 (IPTS-68)	(-200 to 630) °C (-320 to 1160) °F		
Pt100 .00392 (IPTS-68)	(-200 to 960) °C (-320 to 1760) °F	4 Readings / Second ± 0.5 °C + (0.1 % of FRS)	
Pt100 .00393 (ITS-90)			
Ni 100 .00618 (DIN)			
Ni120 .00672 (Nickel A)	(-80 to 260) °C (-112 to 460) °F	10 Readings / Second ± 1.0 °C + (0.1 % of FRS)	
Cu100 .00427			
Cu 53 (GOST)	(-50 to 180) °C (-58 to 320) °F		

Key rdg = reading; FSR = Full Scale range ; *1 Only over the range (800 to 1600) °C, *2 cold junction tracking range(0 to 70) °C , *3 Ambient (-10 to 50) °C

Impedance (Thermocouple)	1 MΩ
Open Circuit sensor bias	0.2 uA
Cold junction range	(-20 to 70) °C
Cold Junction Accuracy	± 0.5 °C
Cold Junction Tracking	± 0.05 °C
RTD Connection	2 or 3 wire
RTD Lead Resistance	20 Ω Max
RTD Lead effect	0.015 °C / Ω.
RTD Excitation Current	< 1 mA
Update Rate (Resolution)	1 readings / second (16 Bits) ; 4 Readings / Second (14 Bits) ; 10 readings / Second (12 Bits)
Galvanic Isolation	500 V to output : 3750 V to supply and Relays
Indication (State LED)	Green Flashing = OK Green Solid = input/output error configuration indication refer to manual.

SMART UNIVERSAL SIGNAL CONDITIONER

PROCESS INPUTS

INPUT	RANGE	ACCURACY @ 20 °C	STABILITY WITH TEMPERATURE
50 mV	± 50 mV (Max ± 75 mV)	1 Reading / Second ±0.04% + (0.1% of FRS)	± 0.04 % FSR / °C
200 mV	±200 mV (Max ± 230 mV)		
1 V	± 1 V (Max ± 1.3 V)	4 Readings / Second ± 0.1 % + (0.1 % of FRS)	
10 V	± 10 V (Max ± 11 V)		
mA	± 25 mA (Max ±30 mA)	10 Readings / Second ± 0.2 % + (0.1 % of FRS)	± 0.05 % / °C
Slide Wire	(0 to 100) % (1 to 1000) KΩ pot		± 0.025 % FSR / °C
Ohms	(20 to 400) Ω Max (0 to 480) Ω		

Key - rdg = reading, FSR = Full Scale range

Voltage Input Impedance	1 MΩ
Current Input Impedance	20 Ω
Slide Wire Input Range	1 KΩ to 1000 KΩ Pot
Resistance Connection	2 or 3 Wire
Galvanic Isolation	500 V to output : 3750 V to supply and Relays
Update Rate (Resolution)	1 readings / second (16 Bits) ; 4 Readings / Second (14 Bits) ; 10 readings / Second (12 Bits)

CURRENT OUTPUT

	RANGES mA			Fault /Error Signal mA		
	Min	Max	Min Span	Up	Down	User
(4 to 20) mA	4.0	20.0	-	22.5	3.8	(0.0 to 25) mA
(0 to 20) mA	0.0	20.0	-			
USER	0.0	24.0	0.5			

Type	Two wire current sink; or two wire current source (11 to 30) V dc , 24 V nominal
Supply in sink mode	(11 to 30) V dc , 24 V nominal
Max loop load	Sink mode loop load of 600 Ω @ 24 V ; Source mode 550 Ω
Response time	< 500 ms to reach 95 % of final value ; Start up time < 3 s
Calibration Accuracy	< 500 ms to reach 95 % of final value ; Start up time < 3 s
Loop Effects	± 5 uA
Supply sensitivity	Loop ripple 0.03 % of FSR;
Protection	Supply ripple rejection < ± 5 uA error @ 1 V rms 50 Hz ripple
Galvanic Isolation	Reverse connection and over-voltage protection. Max over voltage current 100 mA.
User Adjust Options	500 V to input : 3750 V to supply and Relays
Current Output Damping	1. Off (Locked)
Stability	2. Push button user adjust at both ± 10 % of zero and ± 10 % of span
	3. Manual Push Button range configuration
	Programmable rise and fall (0 to 250) seconds, for a (0 to 20) mA swing.
	± 5 uA / °C

VOLTAGE OUTPUT

	RANGES V			Fault /Error Signal V		
	Min	Max	Min Span	Up	Down	User
(0 to 10) V	0.0	10.0	-	11.5	0.0	(0.0 to 13)
USER	0.0	12.0	0.5			

Type	Voltage generated across 500 Ω resistor
Min Load	10 KΩ User Configurable correction for Load.
Response time	< 500 ms to reach 95 % of final value ; Start up time < 3 s
Calibration Accuracy	< 500 ms to reach 95 % of final value ; Start up time < 3 s
Galvanic Isolation	± 5 mV
User Trim	500 V (48 Vdc working I/P to O/P) , 3750 V to supply and Relays
Voltage Output Damping	Push button user adjust at both zero and span
Stability	Programmable rise and fall (0 to 250) seconds, for a (0 to 10) V swing.
	± 1mV / °C

SMART UNIVERSAL SIGNAL CONDITIONER

RELAY OUTPUTS

Type Dual Form C relay contacts
 Contact rating (240 V ac rms @ 1 A ; 30 V dc @ 1 A) Resistive Load
 Relay Type Individual relays 1 & 2 high or low level, full range setpoint plus adjustable Hysteresis
 Ranges Setpoint programmed on units, covering full range of input.
 Hysteresis Set in units.
 Isolation To any other port 3750 V
 Delay Programmable on / off delay (0 to 250) seconds for each relay.

SUPPLY

Range (20 to 240) V DC, (20 to 240) V AC 50/60 Hz
 Power 3 W max
 Protection Internal fuse , Over Voltage
 Galvanic Isolation Supply to any port 3750 V

GENERAL

Ambient Operating (-20 to 70) °C (10 to 95) % RH non condensing. Storage (-40 to 85) °C
 Approvals CE tested to BS EN 61326 ; BS EN 61010_1

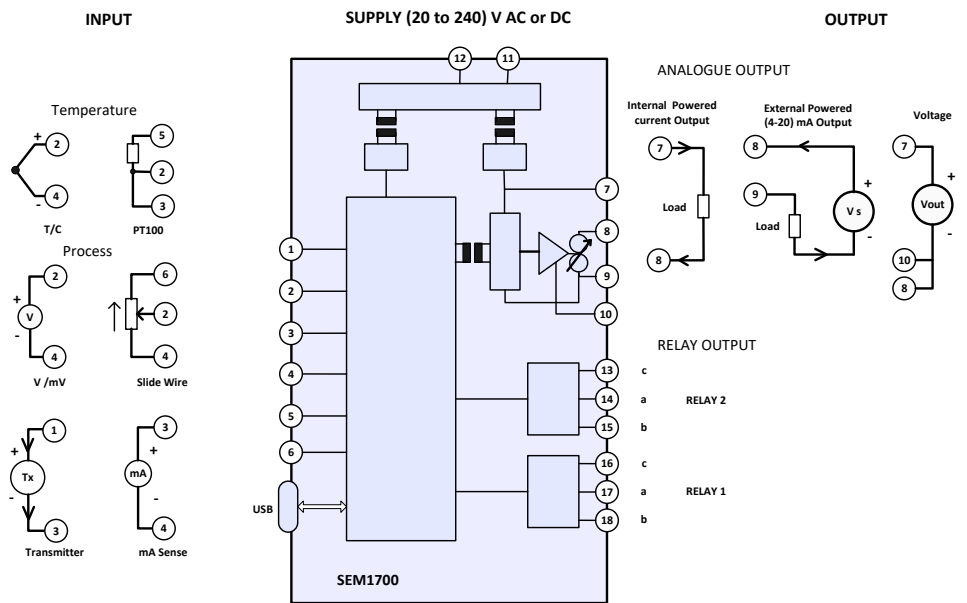

MECHANICAL

(Dimensions in mm)

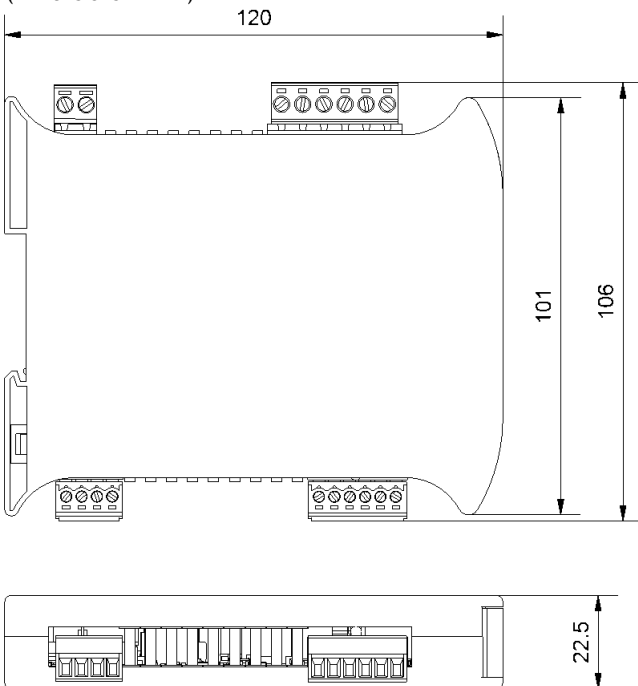

ORDER CODE : SEM1700

ASSOCIATED PRODUCTS

USB CABLE A/M TO MINI B/M
 USB Link Software

ORDER CODES

48-200-0001-01
 FOC @ www.statinst.com Downloads